

KUKA



**The experts in the
heavyweight class**

**KR 360-2,
KR 500-2**

»KR 360-2 AND KR 500-2: THE FLEXIBLE WEIGHTLIFTERS

The world's first heavy-duty robots are really powerful lifters: thanks to their powerful motors and high-performance gear units, they make light work of handling even the heaviest parts. They can effortlessly carry payloads of up to 360 or 500 kg – with impressively high precision and flexibility.

With the same flexibility, they can also be adapted to their environment: for cleanroom requirements or for environments with a high degree of fouling and high temperatures, the robots are also available in the special variants Cleanroom (CR) and Foundry (F). Two arm length variants extend the work envelope in each case, rounding out the wide product range. **The advantages: high degree of planning reliability and security of investment.**

»EXTREMELY COST-EFFECTIVE – EXTREMELY PRECISE

Automatically better: with a KUKA robot you not only have all process steps under control, but also benefit from top performance and flexibility. Thanks to pioneering robotics and control technology, you can rely around the clock on maximum precision – as well as on ease of operation, simple space-saving integration into production sequences, and availability rates of almost 100%. **The advantages: production with greater precision and lower costs.**

»TECHNICAL DETAILS KR 360-2 AND KR 500-2

Dimensions: mm

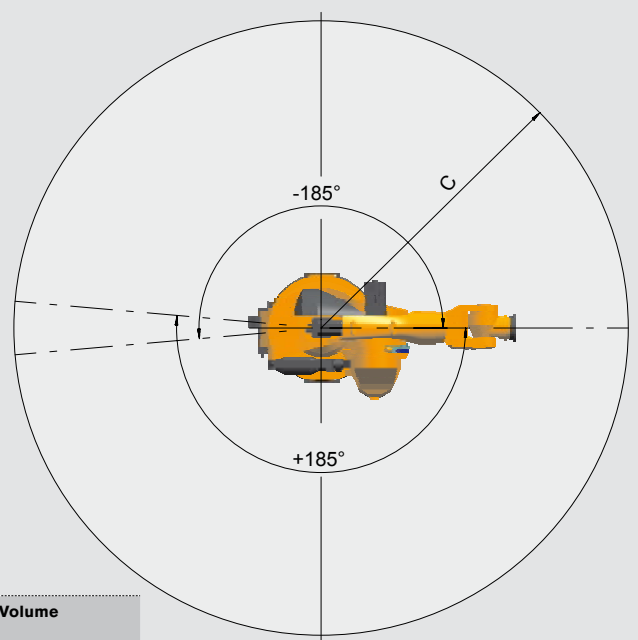
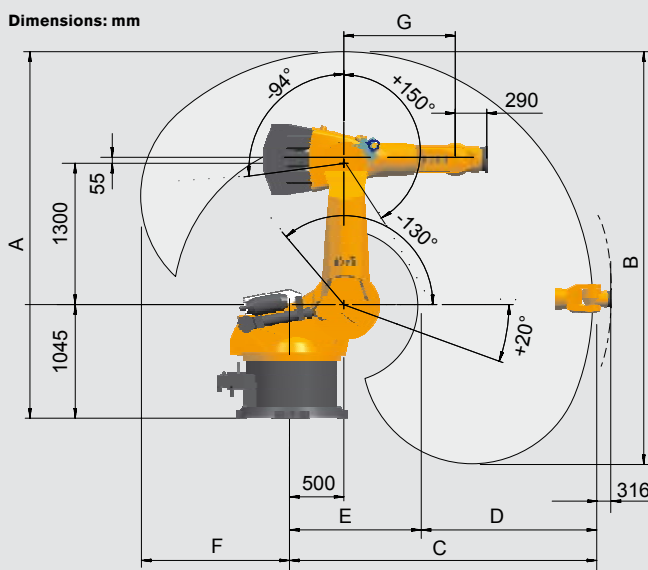

Work envelope	Dimensions ¹⁾							Volume
	A	B	C	D	E	F	G	
KR 360-2	3,371 mm	3,797 mm	2,826 mm	1,614 mm	1,212 mm	1,362 mm	1,025 mm	68 m ³ *; 35 m ³ **
KR 360 L280-2	3,621 mm	4,297 mm	3,076 mm	1,856 mm	1,220 mm	1,612 mm	1,275 mm	91 m ³ *; 50 m ³ **
KR 360 L240-2	3,871 mm	4,797 mm	3,326 mm	2,016 mm	1,310 mm	1,862 mm	1,525 mm	118 m ³ *; 68 m ³ **
KR 500-2	3,371 mm	3,797 mm	2,826 mm	1,614 mm	1,212 mm	1,362 mm	1,025 mm	68 m ³ *; 35 m ³ **
KR 500 L420-2	3,621 mm	4,297 mm	3,076 mm	1,856 mm	1,220 mm	1,612 mm	1,275 mm	91 m ³ *; 50 m ³ **
KR 500 L340-2	3,871 mm	4,797 mm	3,326 mm	2,016 mm	1,310 mm	1,862 mm	1,525 mm	118 m ³ *; 68 m ³ **

¹⁾ Relative to intersection of axes 4/5
 * floor-mounted robot only
 ** ceiling-mounted robot only

»EXTREMELY VERSATILE - EXTREMELY RELIABLE

These high-performers are ready for any job: the KR 360-2 and KR 500-2 can be installed on the floor or ceiling, thus allowing optimal use tailored to your specific cell concept. Arm length variants of up to 500 mm make them even more flexible. Added to this is the precision control, which gives the robots a repeatability of ± 0.08 mm – thus guaranteeing reliable production quality. **The advantages: shorter cycle times and higher quality.**

»EXTREMELY VERSATILE - EXTREMELY SAFE

KUKA offers you a comprehensive range of software: from ready-made application software for the most common applications to simulation programs for planning robot cells and Safe Robot Technology for monitoring safety zones. And for precisely coordinated teamwork with several robots, we offer the RoboTeam application package. **The advantages: maximum scope and maximum safety.**

Type	KR 360-2	KR 360 L280-2	KR 360 L240-2	KR 500-2	KR 500 L420-2	KR 500 L340-2
Maximum reach	2,826 mm	3,076 mm	3,326mm	2,826 mm	3,076 mm	3,326 mm
Rated payload	360 kg	280 kg	240 kg	500 kg	420 kg	340 kg
Suppl. load, arm/link arm/rotating col.	50/100*/400** kg					
Suppl. load, arm + link arm, max.	100 kg*; 50 kg**					
Maximum total load	860 kg	780 kg	740 kg	1,000 kg	920 kg	840 kg
Number of axes	6					
Mounting position	Floor, ceiling					
Variant	Foundry	Foundry	Foundry	Cleanroom, Foundry	Foundry	Foundry
Positioning repeatability*	±0.08 mm					
Path repeatability*						
Controller	KR C2 edition2005					
Weight (excluding controller), approx.	2,350 kg	2,375 kg	2,385 kg	2,350 kg	2,375 kg	2,385 kg
Temperature during operation	+10 °C to +55 °C					
Protection classification	IP 65					
Robot footprint	1,240 mm x 1,240 mm					
Connection	13.5 kVA					
Noise level	< 75 dB					

Axis data	Range (software)	Speed with rated payload					
		360 kg	280 kg	240 kg	500 kg	420 kg	340 kg
Axis 1 (A1)	±185°	89°/s	89°/s	89°/s	69°/s	69°/s	69°/s
Axis 2 (A2)	+110°/-40°*; +50°/-40°**	89°/s	89°/s	89°/s	69°/s	69°/s	69°/s
Axis 3 (A3)	+60°/-184°	93°/s	93°/s	93°/s	69°/s	69°/s	69°/s
Axis 4 (A4)	±350°	109°/s	109°/s	109°/s	77°/s	77°/s	77°/s
Axis 5 (A5)	±118°	112°/s*	112°/s*	112°/s*	76°/s	76°/s	76°/s
Axis 6 (A6)	±350°	157°/s*	157°/s*	157°/s*	120°/s	120°/s	157°/s

Drive system, electromechanical with brushless AC servomotors

²⁾ to ISO 9283

* floor-mounted robot only

** ceiling-mounted robot only

Details provided about the properties and usability of the products are purely for information purposes and do not constitute a guarantee of these characteristics. The extent of goods delivered and services performed is determined by the subject matter of the specific contract. No liability accepted for errors or omissions.



»THE KUKA ROBOT GROUP: YOUR STRONG PARTNER

Quality made in Germany, creativity and the utmost commitment to customers and business partners: these form the basis on which KUKA develops the best possible technologies and thus the optimal automation concepts. The result is that you receive custom-tailored solutions and benefit from decisive process optimization.

Genuine passion for the fascination of robotics is reflected in our slogan “KUKA YOUR IDEAS”, which is also our promise to you: Whatever you want to do, and however unusual your idea may be, with us you can implement anything – irrespective of the specific branch of industry and irrespective of whether or not a similar application has existed before.

Whatever task you give us, KUKA has the required specialists. In close cooperation with experienced system partners with competence in their respective industries, we do everything in our power to implement your ideas. Let us work on them together.

»KUKA SERVICES: ALWAYS THERE FOR YOU

You can rely on us to stand by you in every phase of a project: from planning and commissioning to maintenance and conversion. 24 hours a day. 365 days a year. The high-density KUKA service network ensures that we are always in your vicinity and can start your production in record time.

KUKA YOUR IDEAS

KUKA ROBOTER GMBH

Global Sales Center
Hery-Park 3000
86368 Gersthofen
Germany
Tel. +49 821 4533-0
Fax +49 821 4533-1616
info@kuka-roboter.de

Additional contact addresses:
www.kuka-robotics.com